

Series RO80H 薄膜外殼(高壓型) RO80H Membrane Housing Type(High Pressure) RO80H 膜用ハウジング(高压対応)

設計壓力 Design P. 設計圧力	40kg/cm ²	操作壓力 Operating P. 操作圧力	28kg/cm ²
設計溫度 Design T. 設計溫度	70°C	操作溫度 Operating T. 操作溫度	40°C
標準口徑 Standard Nozzle 標準口徑	N1-1内牙 N2-1 $\frac{1}{2}$ " 機械接頭 N1-1"PT-F N2-1 $\frac{1}{2}$ " V		



RO80H 40 4 25 PF 40 V E 11

產品代碼 Product code 商品コード	管身長度 (英吋) Length of Shell (inch) シェル寸法 (インチ)	材質 Material 材質	N1 規格 N1 Size N1 寸法	N1 類型 N1 Type N1 規格	N2 規格 N2 Size N2 寸法	N2 類型 N2 Type N2 規格	O型環材質 O-ring Material Oリング材質	內面表面處理 Interior surface finished 内面仕上げ
	40 80 120 160 200	4 - 304 6 - 316	25 - 1" 40 - 1-1/2" 50 - 2"	PF - BSPT-F BF - BSPF-F NF - NPT-F V - 機械接頭 J - Clamp	25 - 1" 40 - 1-1/2" 50 - 2"	PF - BSPT-F BF - BSPF-F NF - NPT-F V - 機械接頭 Victaulic coupling J - Clamp	E - EPDM	1 - 酸洗 / 酸洗淨 ACID - Washing 外面表面處理 Exterior surface A finished 外面仕上げ 1 - 酸洗 / 酸洗淨 ACID - Washing

RO80 Membrane Housing Type(High Pressure)

No.	名稱	Description	No.	名稱	Description	No.	名稱	Description
1	束環	Clamp	4	O型環	O-ring	7	機械接頭	Victaulic coupling
2	RO端板	RO head	5	PVC接管	PVC coupling	8	管殼	Shell
3	O型環	O-ring	6	桶唇	Shell flange			

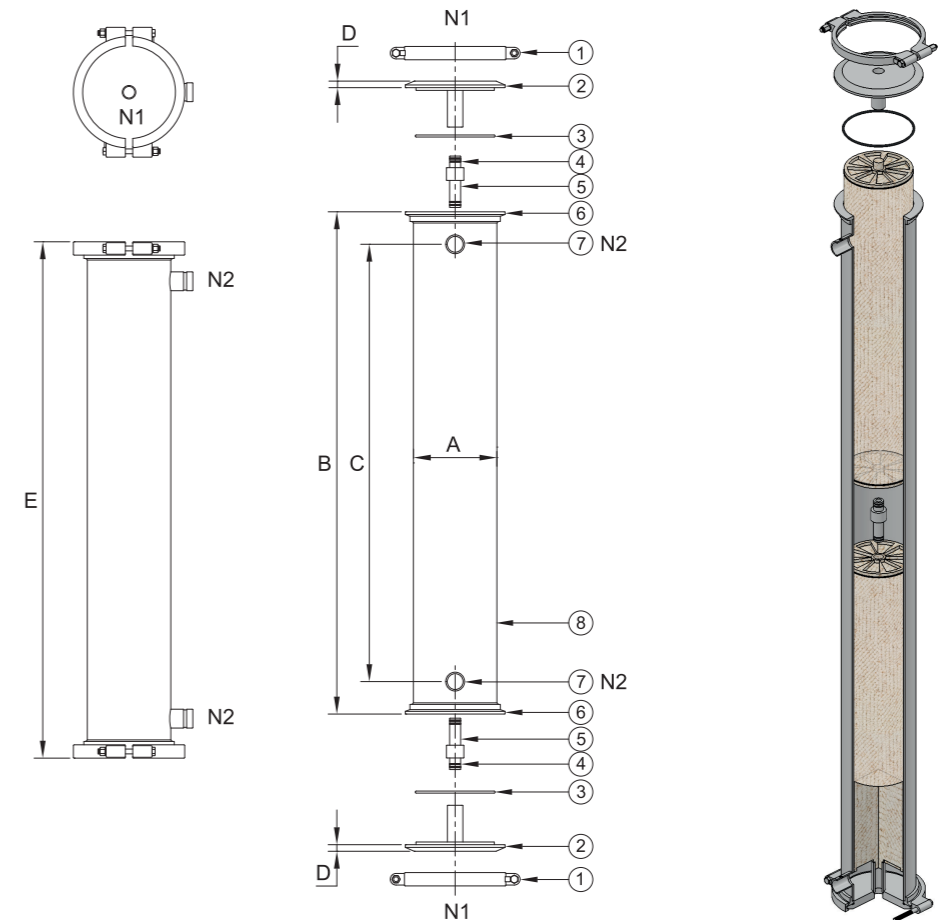

型式 Model	A m/m	B m/m	C m/m	D m/m	E m/m	N1	N2	重量 Weight
RO8040H	Ø216	1300	1132	17	1337	1"	1 1/2"	64kg
RO8080H	Ø216	2316	2148	17	2353	1"	1 1/2"	100kg
RO80120H	Ø216	3332	3164	17	3369	1"	1 1/2"	136kg
RO80160H	Ø216	4348	4180	17	4385	1"	1 1/2"	172kg
RO80200H	Ø216	5364	5196	17	5401	1"	1 1/2"	208kg